

女子団体戦

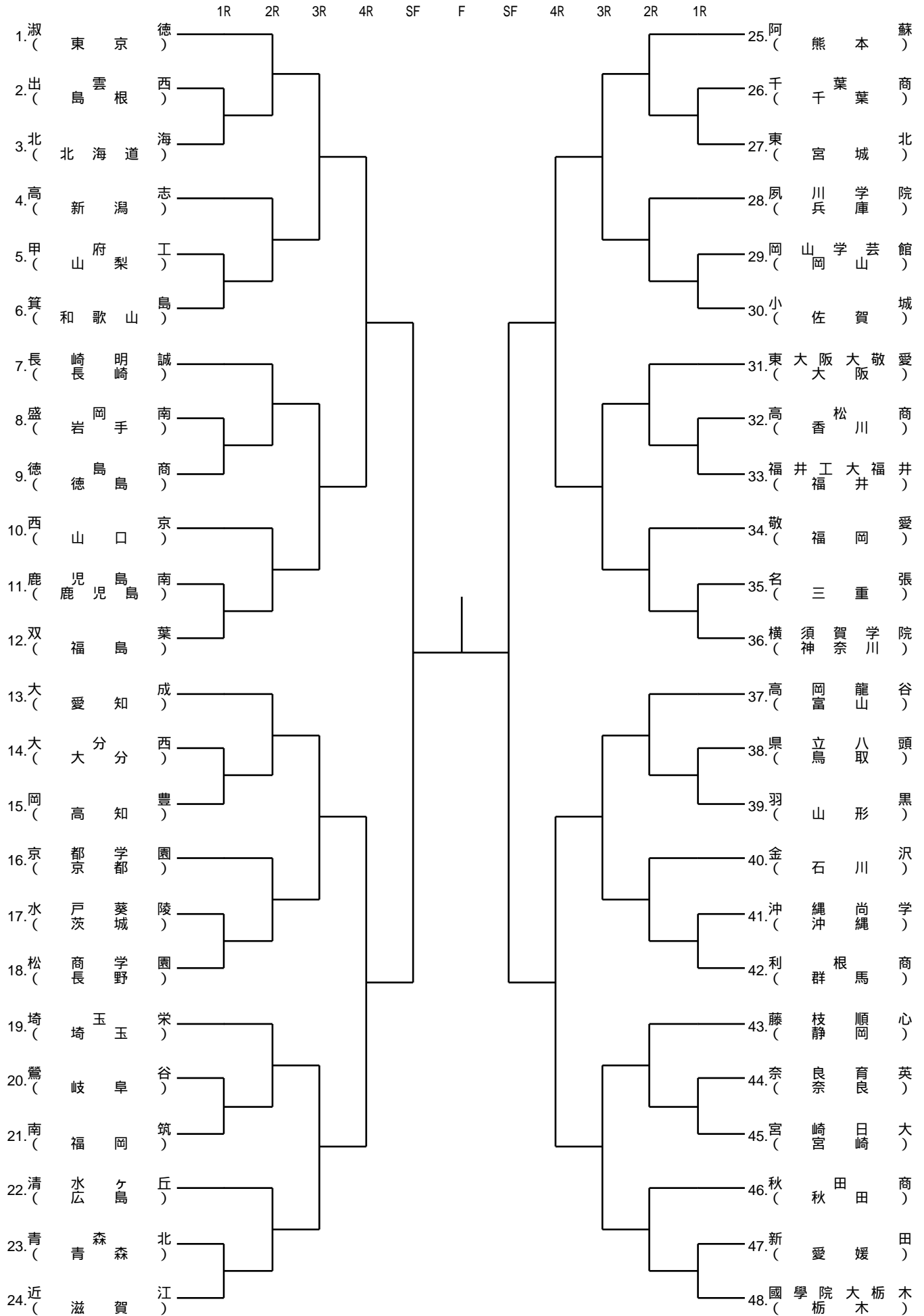

女子 52kg級

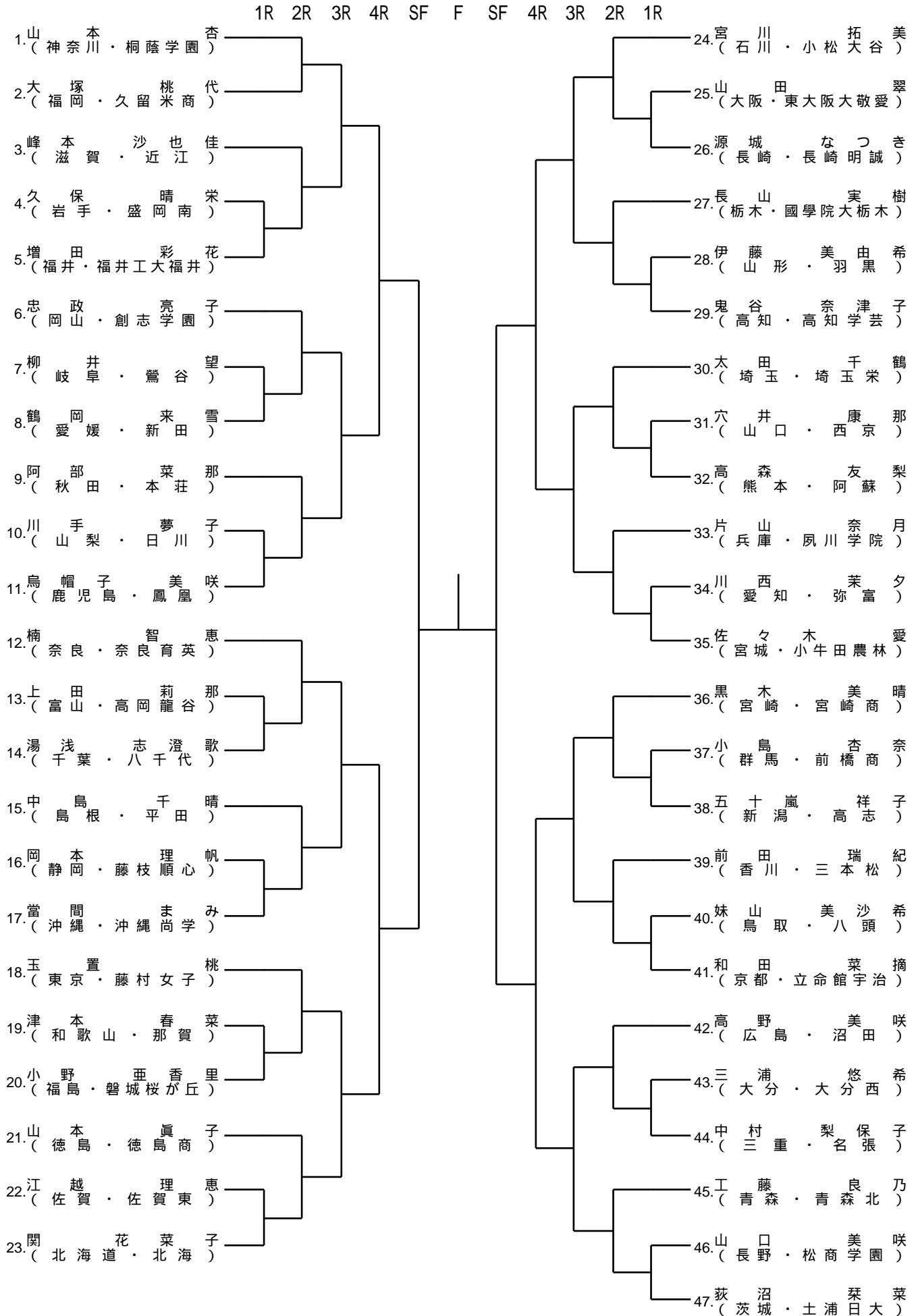

女子 57kg級

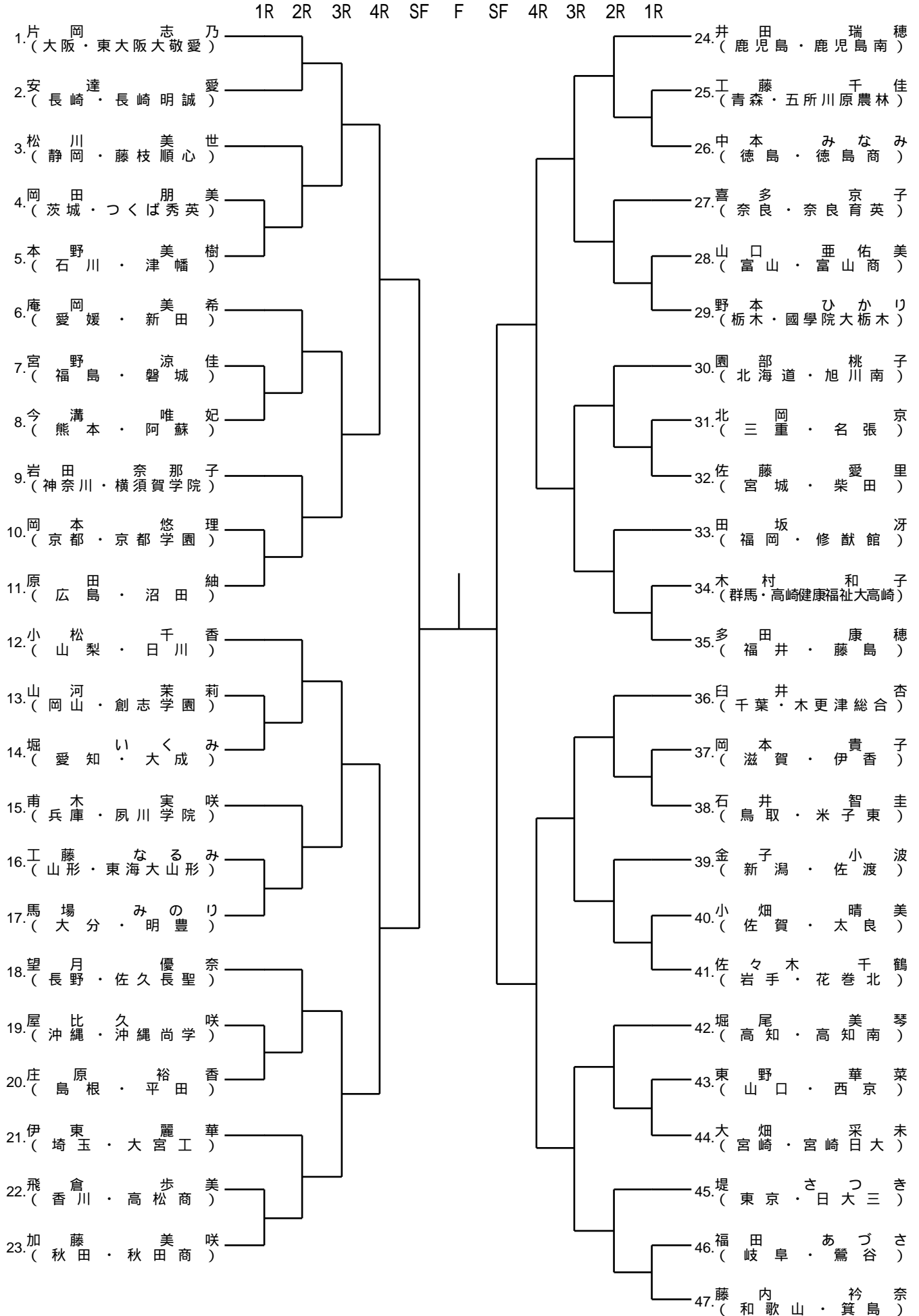

女子 63kg級

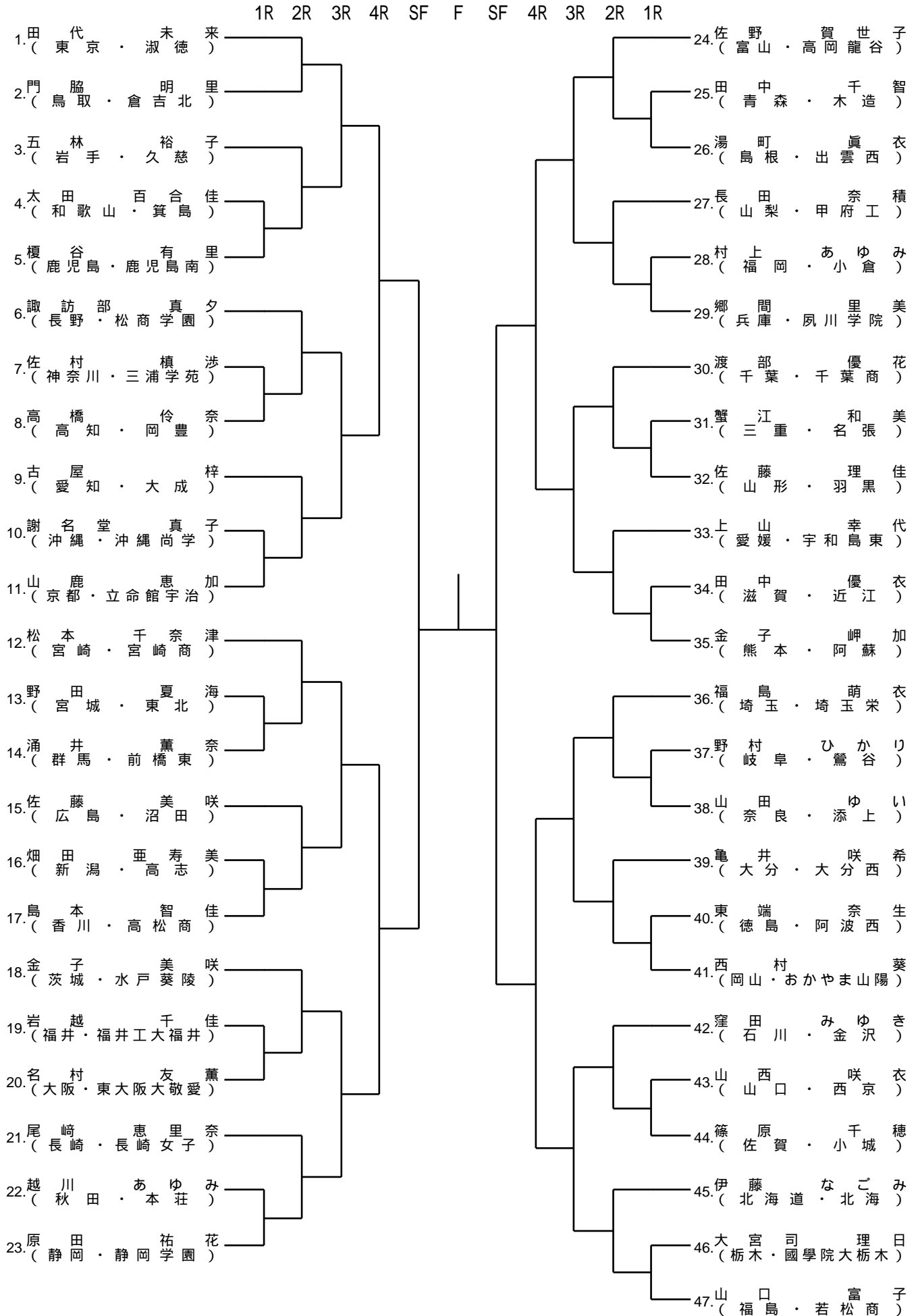

女子 70kg級

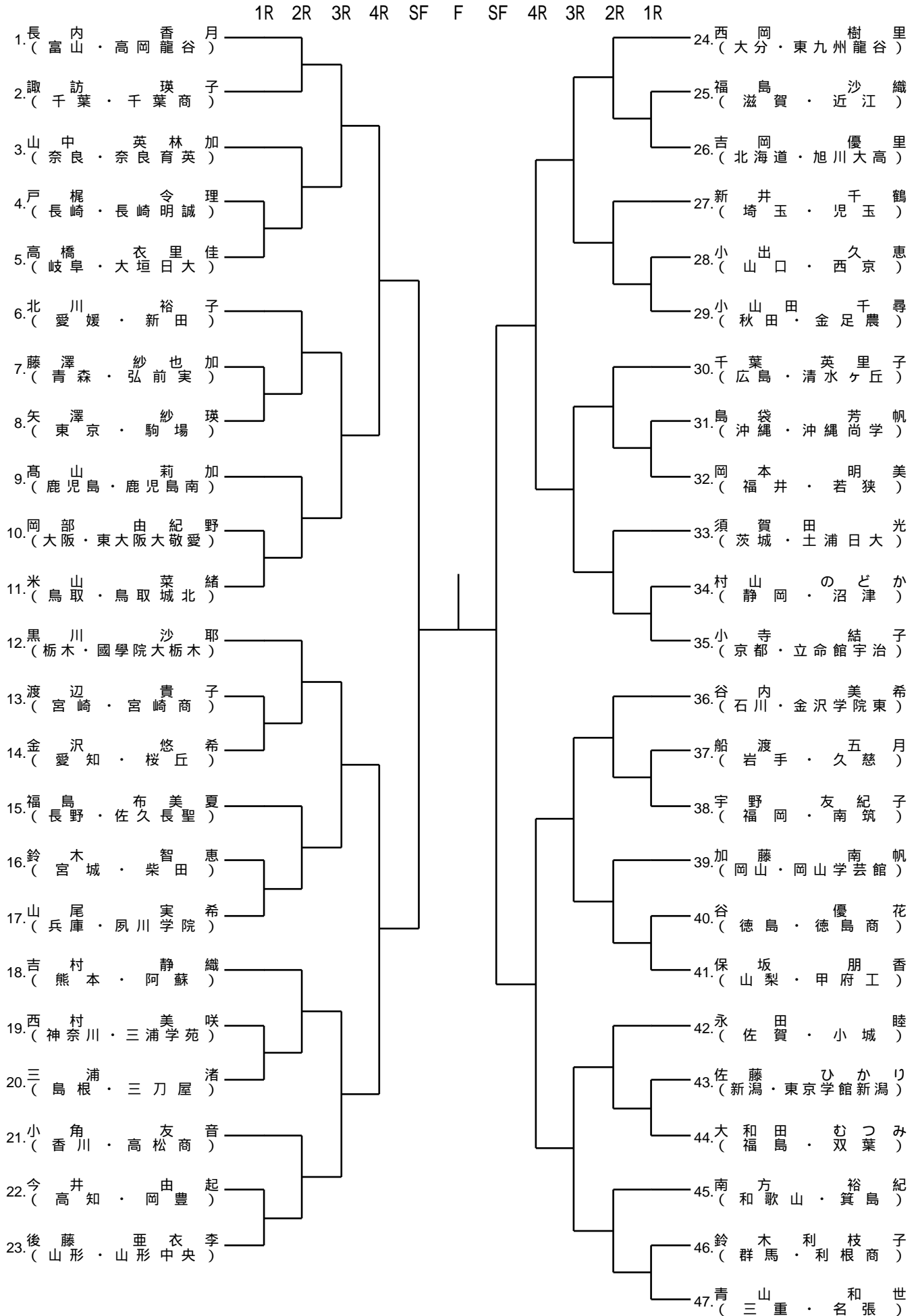

女子 無差別

